

January, 2024

TO: Mansfield® Plumbing Products Sales Team & Distribution Partners

RE: Product Discontinuations

As part of our ongoing efforts to improve our supply chain and optimize production to better serve our valuable customers, we are making changes in the Mansfield Urinals lineup.

The Cascade, 410UHE Urinal, is being replaced by the Cascade II, 414 Urinal, there are some subtle differences in the exterior appearance and the measurements.

CASCADE 410UHE



Product Dimensions (HxWxD):
26-1/4" x 18-5/8" x 14-1/4"

CASCADE II 414



Product Dimensions (HxWxD):
26-3/4" x 18-7/8" x 14-1/2"



To ensure an easy transition in order processing and clear delineation of inventories, we have issued new model numbers.

PRODUCT LINE	FAMILY	PART NUMBER	MODEL	PART DESCRIPTION	COLOR
CASCADE II	URINAL	414010000	414	URINAL 414UHE CASCADE WHT	WHITE

Effective immediately, all new purchase orders should be submitted using the new model numbers referenced below. The customer service team will reach out on a case-by-case basis for any existing orders that need to be adjusted. The pricing of the new models will be the same as the old models.

Please note that there will be no further production of the 410 Urinal Cascade models and we cannot accept returns, so please communicate this change immediately with customers to ensure proper transition of their inventories. If you have ongoing projects or special circumstances to discuss, please reach out your Regional Sales Manager as soon as possible.

Sincerely,



Juan Carlos Suarez
Marketing Director



CASCADE II - 414

URINAL



HALF-STALL, WASH-DOWN, VITREOUS CHINA URINAL

- Top spud, half-stall, wall-mount, wash-down urinal with extended sides
- Complies with ADA requirements for accessibility
- 0.125, 0.5 or 1.0 gpf (when using the proper flush valve)
- Integral trap
- The Mansfield® limited lifetime warranty
- Available in White 
- Substitution for 410 Cascade

SPECS & MEASUREMENTS

URINAL



- Product Dimensions
- (HxWxD): 26 3/4" x 18 7/8" x 14-1/2"
- Specs
- Wall-Mount
- Minimum 0.125 gpf / 0.5 lpf ultra high-efficiency water consumption, depending on flushometer
- Integrated trap
- 2" Outlet
- Includes 3/4" top spud, 2" outlet spud and gaskets, two concealed hangers and bolts

TECHNICAL INFORMATION

URINAL



*Mounting brackets measure 2-7/8" (73MM) in length.

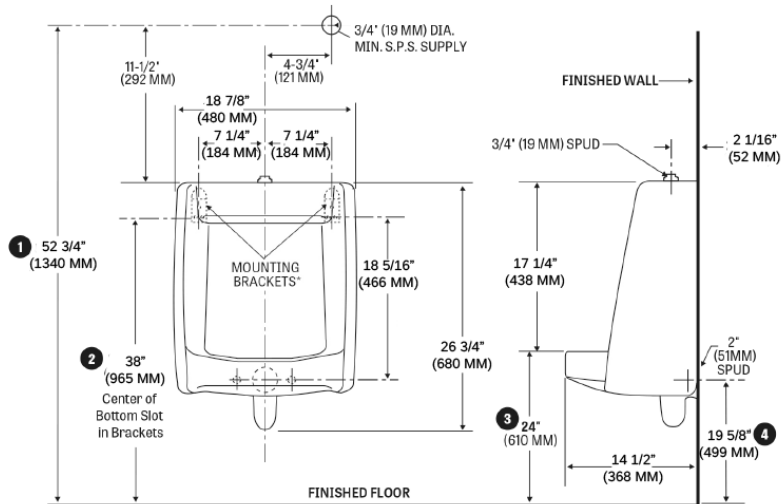

Outlet Detail

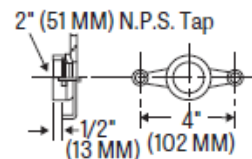

NOTE on Outlet Connection:
2" female threads protrude 1/2" past the urinal.

For ADA Installation, adjust the numbered dimensions as follows:

1	44" (1118 MM)
2	28-5/8" (727 MM)
3	15-1/4" (387 MM)
4	10-9/16" (268 MM)

CODES/STANDARDS



ADA COMPLIANT



UPC



WaterSense



ULTRA HIGH EFFICIENCY URINAL

MANSFIELD®

PARTS & ACCESSORIES

URINAL

PARTS & ACCESSORIES	
471-3265	Urinal hanger (requires set of two)
531-0016	Rear outlet urinal spud kit
24	Urinal top spud - 1" x 3/4" cast brass top urinal spud



CASCADE II 414 – VS CASCADE 410



Dimensions Comparison

CASCADE II - 414	
Height	26/ 3/4"
Width	18 7/8"
Depth	14 1/2"
Weight	58.6 LBS

VS

CASCADE - 410	
Height	26 1/4"
Width	18 5/8"
Depth	14 1/4"
Weight	60 LBS

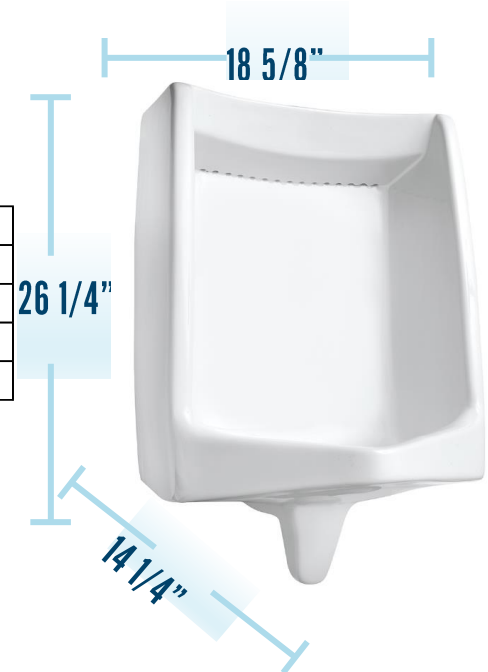

PACKAGING & PALLETS

- Multiregional Kraft Box



DIMENSIONES / DIMENSIONS

637 mm x 362 mm x 472 mm

PESO NETO / NET WEIGHT

28.7 kg approx. / 64.34 lb approx.

PESO BRUTO / GROSS WEIGHT

29.57 kg approx. / 65.46 lb approx.

WARNING:

THIS PRODUCT CAN EXPOSE YOU TO CHEMICALS INCLUDING LEAD, WHICH ARE KNOWN TO THE STATE OF CALIFORNIA TO CAUSE CANCER AND BIRTH DEFECTS OR OTHER REPRODUCTIVE HARM. FOR MORE INFORMATION, GO TO: www.P65Warnings.ca.gov

ADVERTENCIA:

ESTE PRODUCTO PUEDE EXPONERLE A QUÍMICOS INCLUYENDO PLOMO, QUE SON CONOCIDOS POR EL ESTADO DE CALIFORNIA COMO CAUSANTES DE CÁNCER Y EFECTOS DE NACIMIENTO U OTROS DAÑOS REPRODUCTIVOS. PARA MÁS INFORMACIÓN, VISITE: www.P65Warnings.ca.gov

MANSFIELD®
CASCADE URINAL
 0.125 Gpf / 0.5 Lpf
 MODEL NUMBER: 414010080
 MODEL NAME: URINAL 414UHE CASCADE
 COLOR: WHITE

Model 414UHE needs to be used with a flushometer with the same rated flush volume that is WaterSense certified to ensure the combination is in compliance with WaterSense requirements.

WaterSense
 MADE IN NICARAGUA



PALLETS	
PIECES	9
ROWS	3
PIECES X ROW	3



GO WITH

 **MANSFIELD®**